

CONSTRUCT UNIFORM PIPE DEFLECTION – NOT TO EXCEED 75% OF MANUFACTURER RECOMMENDED MAXIMUM DEFLECTION PER PIPE JOINT

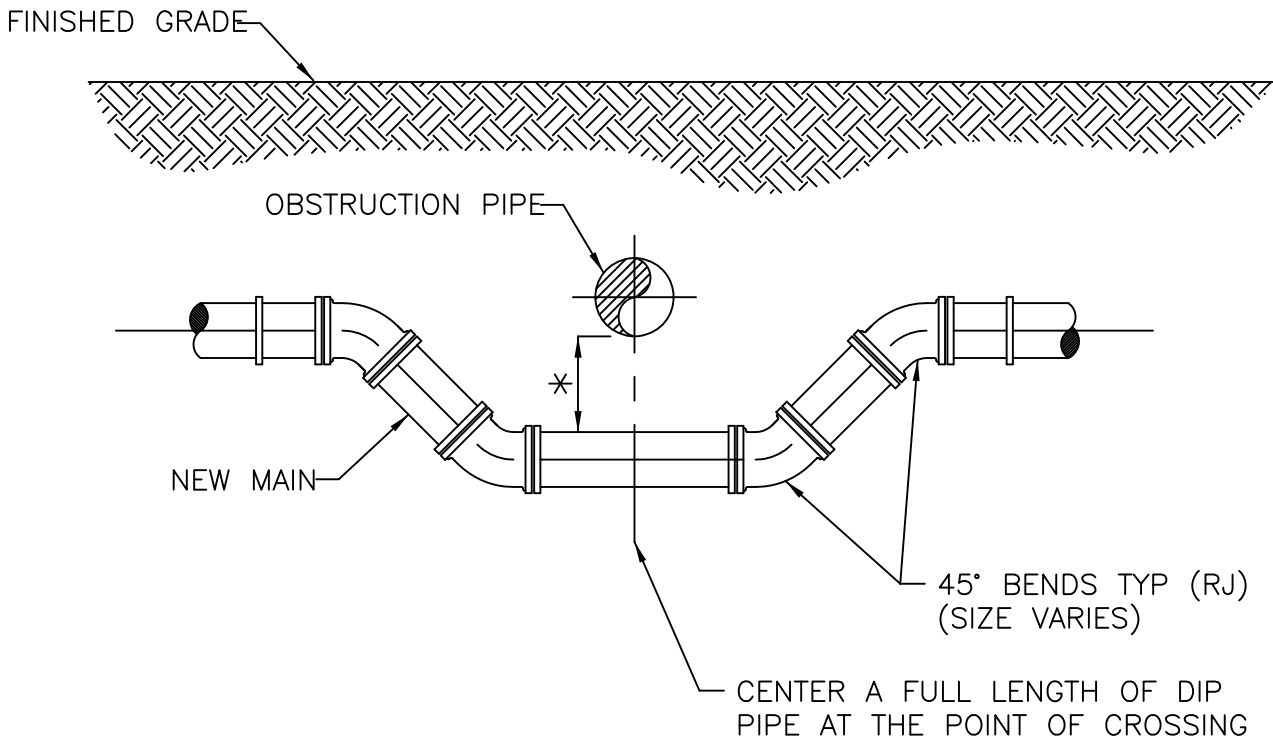
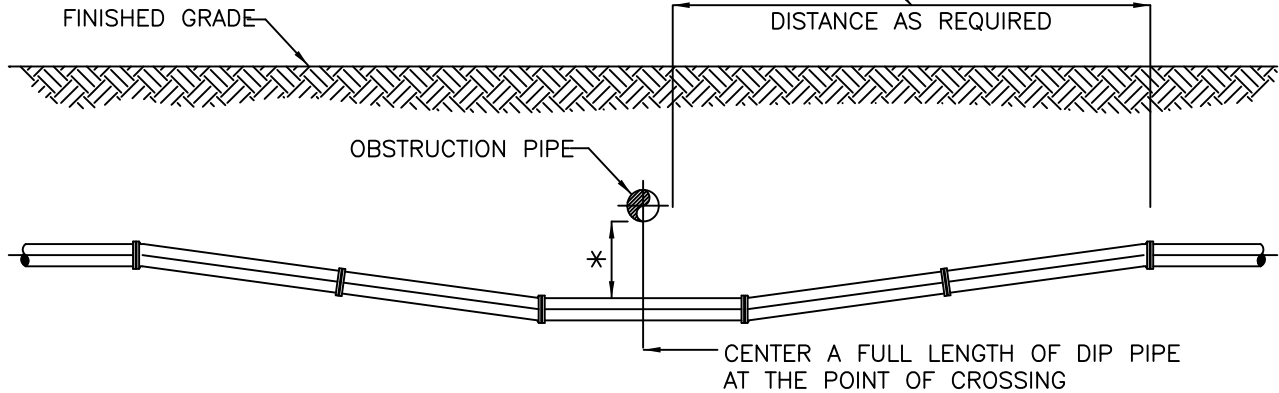

* PIPE CROSSING CONFLICTS WILL BE RESOLVED IN ACCORDANCE WITH THE SEPARATIONS REQUIREMENTS NOTED IN FAC62-555-314(1) AND OR THE FDEP PERMIT. FDEP IS THE SOLE MITIGATION AUTHORITY FOR CONFLICT RESOLUTION AND THE CONTRACTOR WILL SUBMIT REQUEST FOR PIPE SEPARATION MITIGATION THROUGH THE PROJECT ENGINEER TO FDEP. ONLY THE FDEP WRITTEN MITIGATION WILL BE REFLECTED IN THE UTILITY AS-BUILT DRAWINGS. (REF SECT02660)